

ISO VIEW

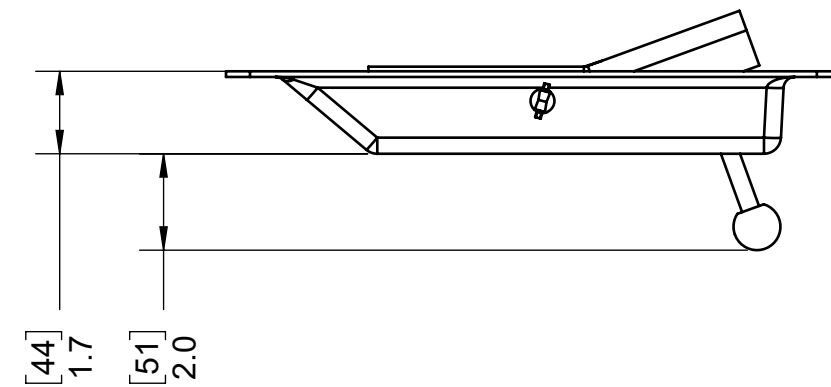
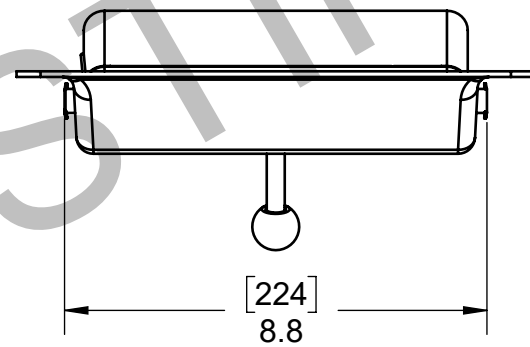

**WEIGHT: 3.93 LBS.**

**MATERIAL: SEE DETAIL DRAWING**

**FINISH: SEE DETAIL DRAWING**

INFORMATION ON THIS DRAWING BELONGS TO AUSTIN HARDWARE AND MAY NOT BE REPRODUCED OR DISTRIBUTED WITHOUT PERMISSION.

TEMPLATE REV 4/7/2011

**DIMENSIONS MAY CHANGE WITHOUT NOTICE**



CREATION DATE: **02-17-2020**

CREATED BY: **dzhang**

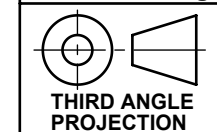

FILE NAME: **Y\_LA-3015-A01**

DESCRIPTION: **LIVESTOCK LATCH ASSEMBLY**

PART NUMBER: **LA-3015-A01**

REV **E**